

 **commodore**

# **VIC-1515**

## **USER'S MANUAL**

**GRAPHIC PRINTER**

by **commodore**

# **VIC-1515**

**GRAPHIC PRINTER  
USER'S MANUAL**

P/N 320838-2

 **commodore**

The information in this manual has been reviewed and is believed to be entirely reliable. No responsibility, however, is assumed for inaccuracies. The material in this manual is for information purposes only, and is subject to change without notice.

©Commodore Business Machines, Inc., April 1981  
“All rights reserved.”

**Commodore Business Machines**  
3330 Scott Boulevard  
Santa Clara, California 95050

## TABLE OF CONTENTS

### Section 1: GENERAL INFORMATION

1. External Appearances and Names of Parts . . . . . 6
2. Function and Operation Method . . . . . 7
3. Interface . . . . . 8
4. Specifications . . . . . 9

### Section 2: PREPARING TO USE YOUR PRINTER

1. Installation . . . . . 11
2. Ribbon Cassete Installation . . . . . 12
3. Paper Instruction . . . . . 12
4. Connecting the Printer to Your Computer . . . . . 15
5. Performing the Printe Power-on Test . . . . . 16
6. Performing the Print head Test . . . . . 16

### Section 3: USING YOUR PRINTER

1. Special Printer-associated Commands . . . . . 19
  2. Printing in the Direct Mode . . . . . 21
  3. Printing under Program Control . . . . . 22
  4. Printing Modes and Control Codes . . . . . 23
    - 4.1 Standard Character Mode . . . . . 24
    - 4.2 Double Width Character Mode . . . . . 25
    - 4.3 Graphic Mode . . . . . 25
    - 4.4 Print Position Determination . . . . . 26
    - 4.5 Print Start Position-Dot Adress . . . . . 28
    - 4.6 Pepetition of Graphic Data . . . . . 29
    - 4.7 "CURSOR UP" Mode . . . . . 30
    - 4.8 "CURSOR DOWN" Mode . . . . . 30
    - 4.9 Reverse Field Mode . . . . . 31
    - 4.10 Reset the Reverse Field Mode . . . . . 31
    - 4.11 Mixture of Various Print Mode . . . . . 32
    - 4.12 Line Feed Spacing . . . . . 32
    - 4.13 Data Buffer Size . . . . . 32
  5. Automatic Printing . . . . . 32
- APPENDIX A VIC-1515 Code Table . . . . . 35
- APPENDIX B Hard Copy of the Screen . . . . . 37

## Section 1: GENERAL INFORMATION

With the purchase of a Commodore VIC Printer, you have added a great deal of versatility and convenience to the use of your Commodore VIC-20 Computer. While this manual contains all the information you need to check out, connect and operate your printer, you should also refer to other Commodore manuals to get the most out of your computer system.

Your VIC printer is designed to operate through software control. It prints upper- and lower-case alphabetic characters, numeric characters, and all the graphic characters available on your VIC-20 computer, and even a custom user-defined graphics. Additionally, your printer has many printing function owing to its own internal microprocessor system.

Your printer contains a microprocessor system that resets the initialization sequence when power is applied. In addition, it contains a random access memory (RAM) in which you can store printing data. Because your printer is an "intelligent" peripheral, it uses none of your computer's memory.

This printer conforms to serial bus requirements and may be connected directly to your VIC-20 computer. The printers, designed to be used with the VIC-SINGLE Floppy Disk Drive, may be daisy-chained with other serial bus devices.

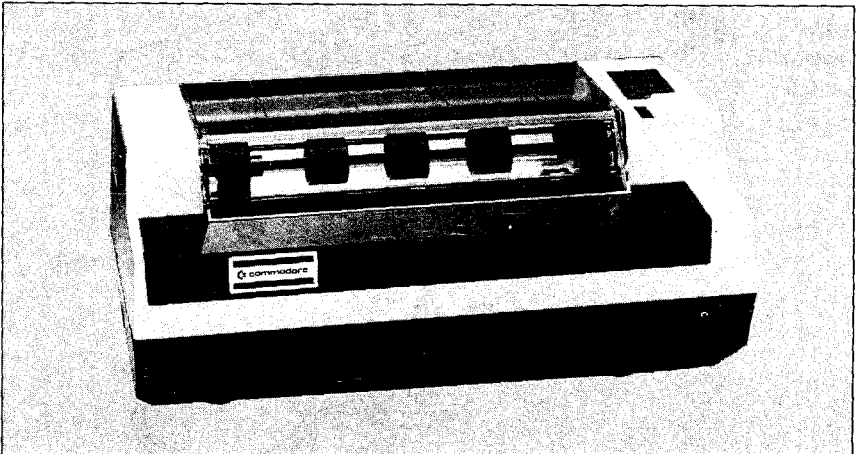

# 1. External Appearance and Names of Parts

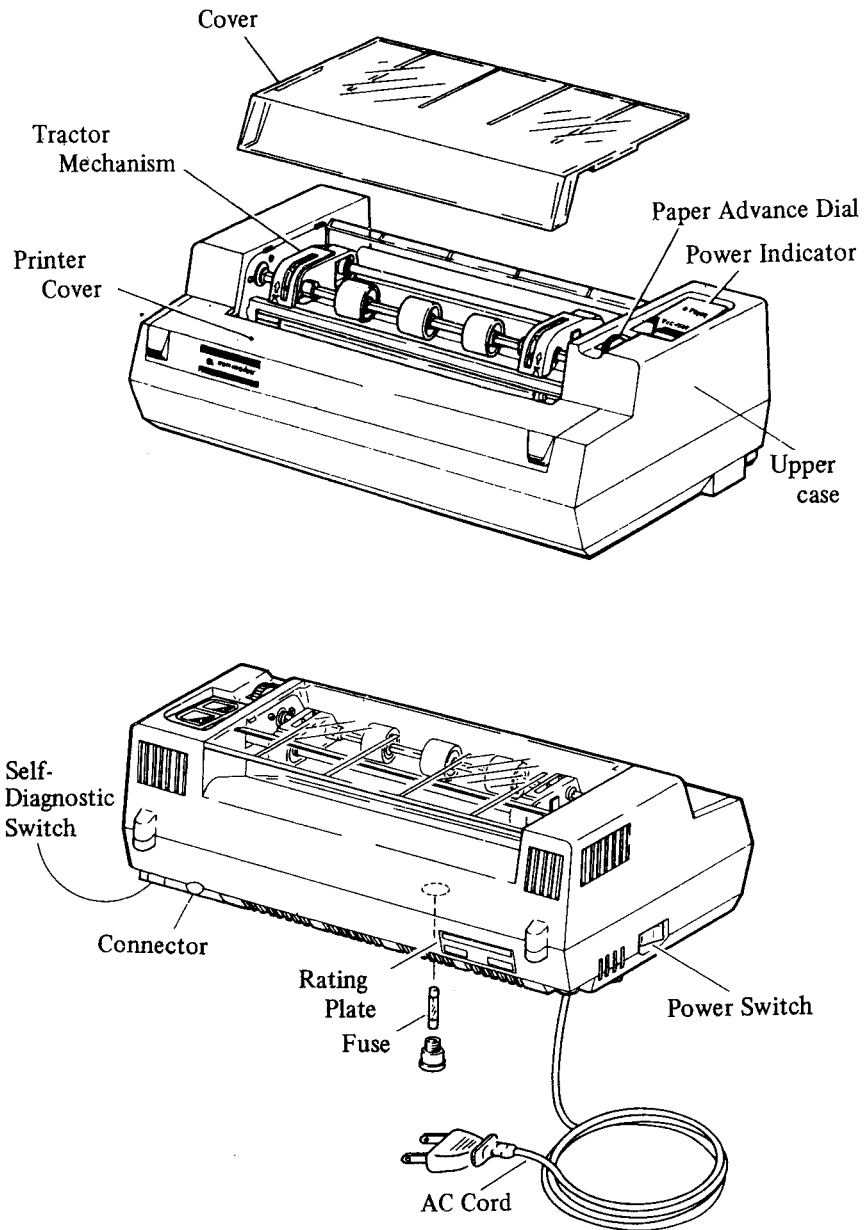

## 2. Function and Operation Method

- a: **Power Switch** : Power Switch is located at the left lower part of the case.
- b: **Power Indicator** : When turned on, this power indicator lights up.
- c: **Self-Diagnostic Switch** : This switch is used to select the device number (4 or 5) or the self-diagnostic test.



- d: **Cover** : For the protection from the dust and also it reduces noise level.
- e: **Printer Cover** : When the inked ribbon is replaced, please remove this printer cover as shown below:

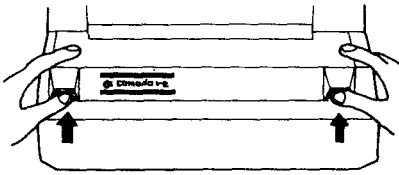

To remove

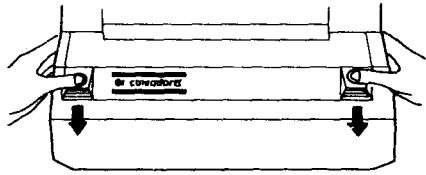

To put it on

- f: **Paper Advance Dial** : The paper can be advanced only forward by this dial.
- g: **Fuse** : Fuse is located at the bottom of the case. (0.5A)

### 3. Interface

#### 1. Connector

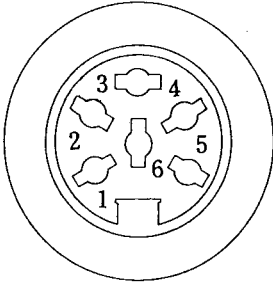

Pin No.	Signal
1	SERIAL SRQ
2	GND
3	SERIAL ATN
4	SERIAL CLK
5	SERIAL DATA
6	RES

#### 2. Interface

- Use the enclosed connecting cable to connect the printer with your computer. Use your computer's serial bus for the connection.
- The device number can be selected by the self-diagnostic switch. (4 or 5)



- The secondary address (SA) can be either 0 or 7.

SA = 0: "CURSOR UP" Mode

SA = 7: "CURSOR DOWN" Mode

- Data will not be transferred when the printer is "BUSY". Therefore, when printing, DATA line will be kept "LOW" and when not printing, it is kept "HIGH".
- When a printer error condition occurs, all the control circuits internal to the printer halt.



## 4. Specifications

### 1. General Specifications

- A. Print method . . . . . Impact dot matrix print(uni-hammer method)
- B. Character Matrix . . . . . 5 x 7 dot matrix
- C. Characters . . . . . upper/lower case characters, numerals symbols, and PET graphic characters
- D. Graphics . . . . . Dot addressible. 7 vertical dots per column, max 480 columns.
- E. Character codes . . . . . VIC-20 8-BIT CODE
- F. Character size . . . . . Height: 7 dots (2.82 mm)  
Width : 5 dots (1.76 mm)
- G. Print speed. . . . . 30 characters/sec (left to right, uni-directional)
- H. Max. number of columns . . . . 80 columns
- I. Character spacing . . . . . 12 characters/inch
- J. Linefeed spacing . . . . . 6 lines/inch . . . . . Character mode  
9 lines/inch . . . . . Graphic mode
- K. Linefeed speed . . . . . 5 linefeeds/sec . . . . Character mode  
7.5 linefeeds/sec . . . . Graphic mode
- L. Paper feed . . . . . Pin feed
- M. Paper width . . . . . 4.5 to 8 inches acceptable
- N. Multiple copies . . . . . Original plus 2 copies
- O. Inked ribbon . . . . . Single color, inked roller built-in cassette type
- P. External dimensions . . . . . 172.5D×328W×132 H mm
- Q. Weight . . . . . Approximately 2.5 kg

### 2. Operating Environment

- A. Power requirements . . . . . 120V (USA), 220 ~ 240V (Europe)  
AC ± 10%, 50/60 Hz
- B. Power consumption . . . . . 15 watts max. (character printing)  
. 5 watts (idling)
- C. Temperature . . . . . 5°C ~ 40°C
- D. Humidity . . . . . 20% ~ 80% (no condensation)

## Section 2: PREPARING TO USE YOUR PRINTER

### 1. Installation

When you set up VIC-1515, please follow the cautions as below:

- \*Please place the printer on a flat surface.
- \*Please avoid high humidity, dust and direct sun light.
- \*Also please avoid a drastic temperature change.

### 2. Ribon Cassete Installation

- (1) Locate the ribbon cassettes which are packed in the carton separately from the Printer.
- (2) Place the ribbon cassettes so the protusions are facing the front side of the Printer.
- (3) Remove the soundproof cover and the cover.
- (4) Place the ribbon cassettes in the positions ① , ② , and ③ as shown in the figure below.

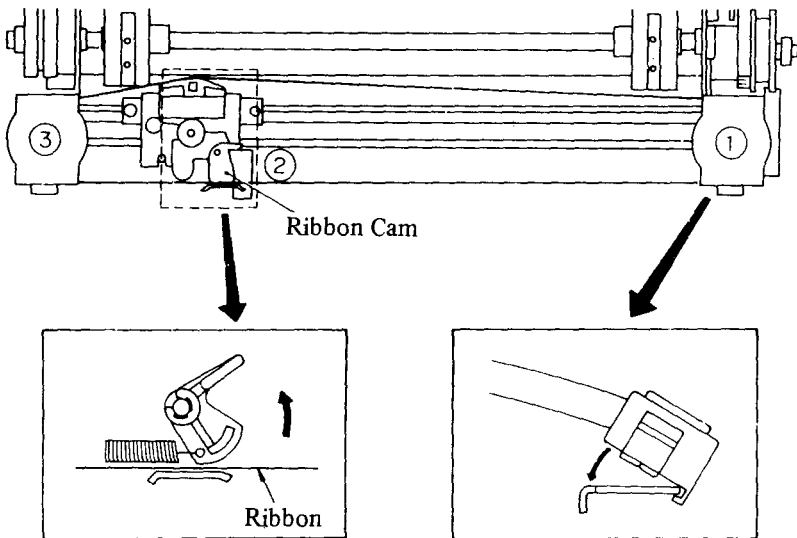

- NOTES:**
1. Make sure that the ribbon is not twisted.
  2. You can not install the ribbon cassettes if the left and the right cassettes are reversed.
  3. **Do not try to move the print head manually.**  
**Forcing it to move may damage the Printer**
  4. Raise the inner side of the ribbon (the plate side) a little for easier removal and/or installation.

When replacing a worn-out ribbon, use only the specified replacement ribbon. Remove the old ribbon following the above procedure in reverse and replace it with the new ribbon.

### 3. Paper Instructions

#### 3.1 Recommender Paper

- Use paper that conforms to the following specifications.
 

Paper width . . . . .	Paper width 4.5" – 8"
	Pin to pin 4" – 7.5"
Paper thickness . . . . .	.07 – 0.09 mm for single part
	0.075 mm (45 kg) paper is recommended
- Exclusive paper for VIC-1515 is provided.  
Continuous business forms with sprocket feed holes in both sides 8"×6" (W×L), 45 kg, and 1000 refolded sheets per unit
- Copy paper (1 original + 2 copies)
 

Original . . . . .	.35 ~ 40 kg (0.06 ~ 0.07 mm)
Copies . . . . .	.30 ~ 35 kg (0.055 ~ 0.06 mm)

In the case of three parts, the total thickness of paper should be less than 0.2 mm.

#### 3.2 Paper Loading Instructions

Turn off the power switch before loading the paper

- (1) Remove the soundproof cover.
- (2) Line up the paper holders on both sides.
- (3) Adjust the sprocket unit spacing to accommodate the paper so that the paper will be neither stretched too tightly nor loose and wrinkled.

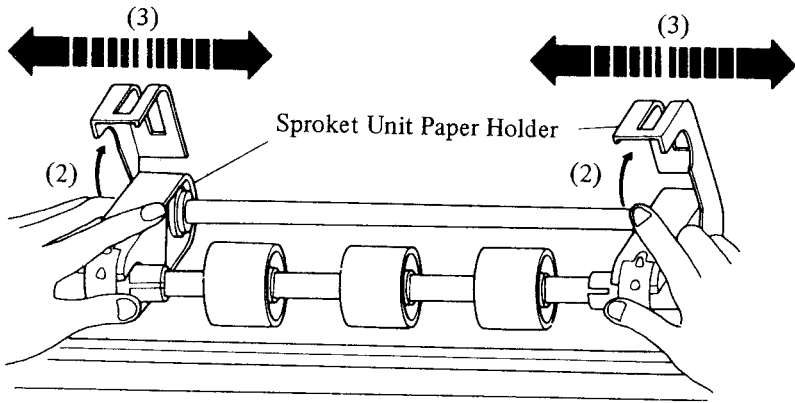

- (4) Insert the paper from the rear of the Printer.
- (5) When the paper comes from between the ribbon and the platen, hold up the bar
- (6) Place the paper beneath the bar and fit it over the sprocket pins
- (7) Lower the bar and the paper holders

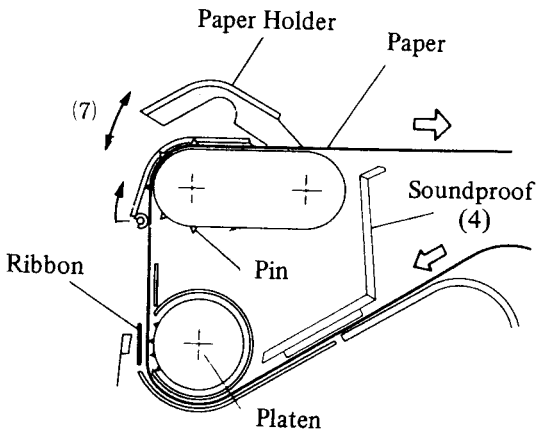

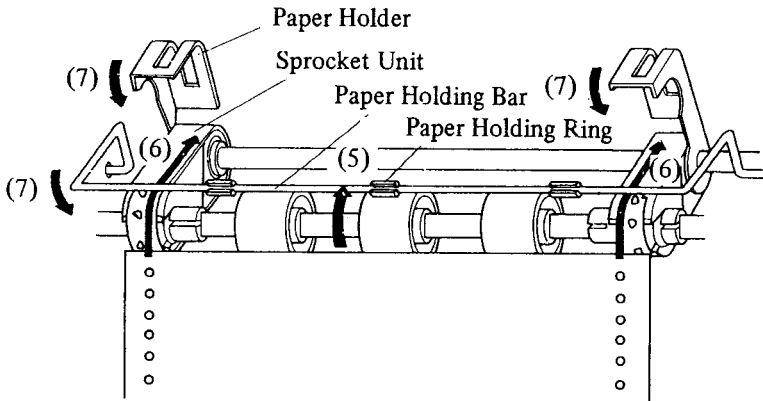

- (8) The three paper holding rings can be moved along the bar. Adjust their positions in accordance with the paper width. Make sure that the rings are not under the paper holders. By using this bar, during printing, the paper is securely held and the paper vibrating noise is reduced.
- (9) Manually set the position of the paper by rotating the paper feed dial forward. See the Figure below.

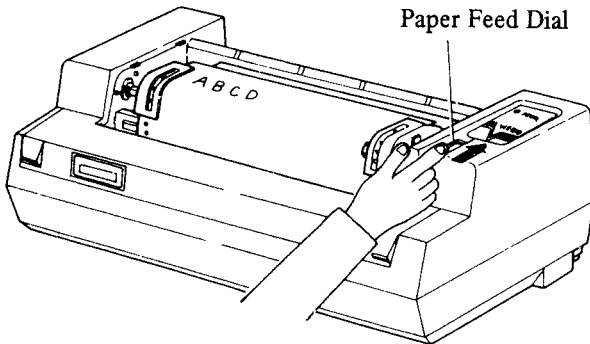

- (10) Put on the soundproof cover.  
**NOTE:** Keep the paper to be fed into the Printer in line with the sprocket pins so that it will feed smoothly.

### 3.3 Printing Pressure Adjustment

You may adjust a lever on the print head according to the thickness of the paper. When you are using single part paper position 1 will be appropriate. When adjusting the lever, make sure that it is placed directly in the desired click hole, not between two of them.

**CAUTION:** Do not try to move the print head manually.

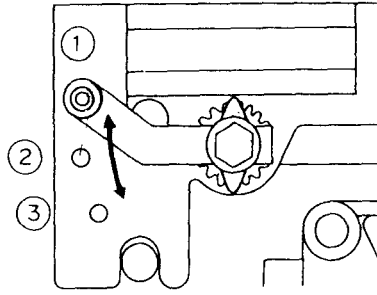

### 3.4 Print Starting Position

As described below, printing starts at the position about 30 mm away from the left-edge of the Printer.

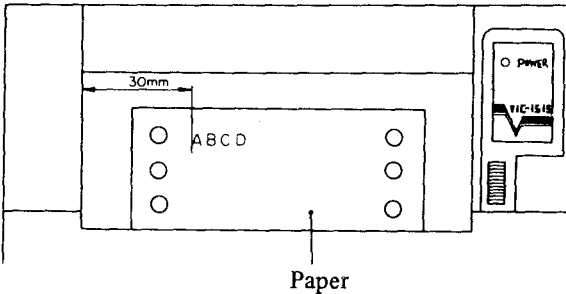

## 4. Connecting the printer to your computer.

Please follow the procedure as below:

- 1: Turn off your computer.
- 2: Connect your computer with your printer by the enclosed cable.
- 3: Connect the power cord of your printer to the AC outlet.

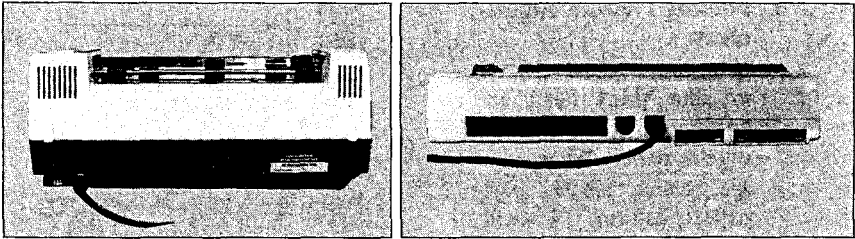

## 5. Performing the Power-on Test

(Please do not turn on your computer at this stage yet.)

1. Turn your printer on.
2. The print head will move to the center of the carriage automatically and then return to the original position. If the print head does not move as described above, please check whether or not the connecting cable is properly plugged in. Then, repeat the above once more.

## 6. Performing the print Head Test

You can test the print head (and the ribbon as well) after you have inserted the paper. Never allow any printing occur when there is no paper. To do so may result in damage to the print head. To perform this test, flip and self-diagnostic switch to "T" position.









## Section 3:

# USING YOUR PRINTER

Your printer does much more than just give you clean, fast copy. Since it has its own internal microprocessor system, it is very versatile. In this section you will learn how to use your printer to print outlistings, program results, and graphic displays. You will learn how to use it to double width character. You will even be able to create your own custom graphic.

Before you attempt to use your printer, make sure you know how to do the following:

1. Operate your Commodore computer.
2. Do elementary programming in BASIC.
3. Write files to and from a peripheral device such as the tape cassette recorder.
4. Open and close files.

You should refer to your computer User Manual for this information.

### 1. Special Printer-associated Commands

When you want to print something on your printer, essentially what you are doing is transferring the video screen function to the printer. A few special BASIC commands allow you to make this transfer. Most other BASIC considerations and rules remain the same. Always remember to press the **RETURN** key after you type each command.

### The OPEN Command

The syntax of the OPEN command is:

OPEN *lfn*, *dn*, (*sa*)

This command sets a correspondence between a file number and a physical device. The *lfn* or *logical file number* may be any number you choose to assign to your file from 1 to 255. It doesn't matter which number you choose as long as you remain consistent throughout your set of commands. The *dn* or *device number* (also known as the primary address) refers to the device to which you wish to send the file. In the case of VIC-1515 printer, the number is either 4 or 5.

The SA or secondary address is somewhat of a unique concept. It alerts the Printer's microprocessor system that formatting is to occur. With VIC-1515,

you can select either one of the following two modes.

- 0 : "CURSOR UP" Mode
- 7: "CURSOR DOWN" Mode

## The CMD Command

The syntax of this command is:

CMD *lfn*

CMD transfers control from the computer to the printer. The *lfn* must be the same as that in the OPEN statement with which it is associated. Unlike a PRINT command, the line or bust to the receiving device is left open. The line or bus to the receiving device (in this case, the printer) is said to be "listening." When you give the CMD command, the printer prints READY and the printer is waiting for further commands. If you follow a CMD command with a PRINT or a LIST command, the output is directed to the printer.

## The PRINT # Command

The syntax of the PRINT # command is:

PRINT # *lfn, data*

PRINT # works just like PRINT except that it directs output to the printer instead of the video screen. The line to the printer is closed after printing the designated data. The line or bus to the printer is said to be "unlistened." Therefore, if you have used the CMD command, it is the printer and the computer.

NOTE: In CBM BASIC V2, the PRINT command can be abbreviated as a question mark(?). You may not do this with PRINT#. It must always be typed out as PRINT#.

# The CLOSE Command

The syntax of this command is:

```
CLOSE lfn
```

You should always close a file after printing from it. You may not exceed ten open files so it is well to make a habit of closing files when you are finished with them. This way you will always have the maximum number of files available for use. As you shall see later, one file may be open under several logical file numbers at one time.

Remember, since CMD does not close the line to the printer, you must always precede a CLOSE command with PRINT # in order to properly close the file.

Example :

Right	Wrong
OPEN 5, 4 PRINT #5, "HELLO VIC" CLOSE 5	
OPEN 5, 4 CMD 5, "HELLO VIC" PRINT #5; CLOSE 5	OPEN 5, 4 CMD 5, "HELLO VIC" CLOSE 5
OPEN 5, 4 PRINT #5, "HELLO VIC" CM 7 PRINT #5	OPEN 5, 4 PRINT #5, "HELLO VIC" CMD 5, "HELLO VIC" CLOSE 5

Armed with these thumbnail descriptions of what the printer-related commands do, you can now proceed to the next part of this section, which tells you how to use these commands to control your printer. You can find more detailed information about these commands in your computer User Manual.

## 2. Printing in the Direct Mode

The direct mode of communication allows you to enter printing commands at the keyboard.

The following example shows the entire direct mode listing process of a short BASIC program. A file containing a single BASIC statement is typed into the computer's memory. The file is opened, the output channel is opened, and the file is listed. After the file is listed, the output channel is closed and the file is closed. The printer is now out of use and the computer is ready to accept new commands.

	You type:	The screen displays:	The printer prints:
①	10?"TEST"	10?"TEST"	
②	OPEN3,4	OPEN3,4 READY.	
③	CMD3	CMD3	READY.
④	LIST	LIST	10 PRINT"TEST" READY.
⑤	PRINT#3	PRINT#3	
⑥	CLOSE3	CLOSE3 READY.	

- ① You place the data in the computer's memory.
- ② You open the file and give it a LFN of 3. The 4 makes the file available to the printer.
- ③ The printer is "listening."
- ④ The program is printed on the printer. The printer is still "listening."
- ⑤ Use the PRINT# command to "unlisten" the printer.
- ⑥ You close the file so that LFN 3 can be used for something else.

### 3. Printing under Program Control

As we have seen, you can control the printer directly from the keyboard. You can also control the printer from within a BASIC program. In the example below, this short BASIC program is placed in the computer's memory. (It could have been placed there from the keyboard, a cassette tape, or a floppy disk):

```
10 OPEN3,4
20 CMD3
30 PRINT"PROGRAM CONTROL"
40 LIST
```

The RUN command is given and the resulting printout is shown here:

```
PROGRAM CONTROL
```

```
10 OPEN3,4
20 CMD3
30 PRINT"PROGRAM CONTROL"
40 LIST
```

```
READY.
```

REMEMBER THIS: The LIST command within a program execution. Then, when you are finished running a program, you must type the PRINT# command to close the channel. Then type the CLOSE command to close the file.

#### 4. Printing Modes and Control Codes

Besides standard characters, VIC-1515 can do the following which can be selected by control codes with PRINT # (CMD or PRINT).

1. Double width character output under software control.
2. Graphics capability (picture and graph output capabilities).
3. In the graphic mode, a graphic data pattern can be repeated as many times as you want with a single command.
4. Print position addressable by character or dot column (positioning control).
5. Graphic, character, and double width character modes can be inter-mixed on a single line.
6. Reverse field characters printing.
7. Automatic Printing, when the text exceeds the maximum line length no data is lost due to overflow.
8. Self-test printing is available.

## CONTROL CODES

Codes	Input Code	Description
NL	CHR\$(10)	Line feed after printing
CR	CHR\$(13)	Ditto
BS	CHR\$(8)	Graphic mode command
SO	CHR\$(14)	Double width character mode command
SI	CHR\$(15)	Standard character mode command
POS	CHR\$(16)	Print start position addressing
ESC	CHR\$(27)	When followed by the POS code it is used to specify a start position according to the dot address.
SUB	CHR\$(26)	Repeat graphic select command
CURSOR UP	CHR\$(145)	Cursor up mode command
CURSOR DOWN	CHR\$(17)	Cursor down mode command
RVS ON	CHR\$(18)	Reverse field command
RVS OFF	CHR\$(146)	Reverse field off command

### 4.1 Standard Character Mode

When the printer is turned on, it is in the standard character mode. But, once different character modes are selected, the selected mode will remain until the standard character mode is selected again by SI code=CHR\$(15). To print VIC-1515 with double width characters and then to get listing of the program with standard characters, do the following.

## VIC-1515 PRINTER

```
10 OPEN1,4
20 PRINT#1,CHR$(14)"VIC-1515 PRINTER"
30 PRINT#1,CHR$(15)
40 CMD1:LIST
```

READY.

#### 4.2 Double Width Character Mode

SO code=CHR\$(14) will print double width characters.

Example

```
10 OPEN1,4
20 PRINT#1,CHR$(14)"VIC-1515 PRINTER"
30 CLOSE1
```

RUN

**VIC-1515 PRINTER**

#### 4.3 Graphic Mode

With BS code=CHR\$(8), you can print any graphics you may program. Graphics can be made by inputting data, of each lines of dots. Following is the example of how to make COMMODORE's logo.

- 1: To the left of the dots, write the binary bit value of each row.
- 2: Use dots, to create your graphics.
- 3: Add up the binary bits indicated by your dots in each column and 128.
- 4: These totals are used in the DATA statement in your program.

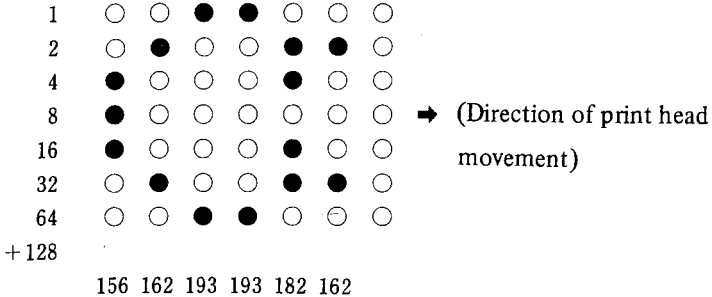

The DATA statement in your program will read:

```
DATA 156,162,193,182,162
```

The following program will print COMMODORE with its logo 4 times.



```

10 DATA156,162,193,193,182,162
20 FORI=1T06
30 READA
40 A$=A$+CHR$(A)
50 NEXT
60 OPEN4,4
70 FORI=1T04
80 PRINT#4,CHR$(8)A$;
90 PRINT#4,CHR$(15)" COMMODORE"
100 NEXT

```

After typing RUN, you get this result:

```

G COMMODORE
G COMMODORE
G COMMODORE
G COMMODORE

```

#### 4.4 Print Position Determination

With POS code=CHR\$(16), the print start position can be determined. By assigning 2-digit number following POS code, the start position can be determined.

Example

```
01234567890123456789012345678901234567890123456789
```

VIC-1515

PRINTER

```

10 OPEN4,4
20 FORI=1T05
30 PRINT#4,"0123456789";
40 NEXT
45 PRINT#4,CHR$(10)
50 PRINT#4,CHR$(16)CHR$(48)CHR$(56)"VIC-1515";
55 PRINT#4,CHR$(16)CHR$(51)CHR$(48)"PRINTER"
60 CMD4:LIST

```

READY.

The print start position can be easily determined as follows:

01234567890123456789012345678901234567890123456789

VIC-1515

PRINTER

```
10 OPEN4,4
20 FORI=1TO5
30 PRINT#4,"0123456789";
40 NEXT
45 PRINT#4,CHR$(10)
50 PRINT#4,CHR$(16)"08VIC-1515";
55 PRINT#4,CHR$(16)"30PRINTER"
60 CMD4:LIST
```

READY.

Two-digit numbers following the POS code are the print start position of the standard characters, which can be proved by the following example.

01234567890123456789012345678901234567890123456789

VIC-1515

PRINTER

```
10 OPEN4,4
20 FORI=1TO5
30 PRINT#4,"0123456789";
40 NEXT
45 PRINT#4,CHR$(10)
48 PRINT#4,CHR$(14)
50 PRINT#4,CHR$(16)"08VIC-1515";
55 PRINT#4,CHR$(16)"30PRINTER"
58 PRINT#4,CHR$(15)
60 CMD4:LIST
```

READY.



The following program will print COMMODORE and its logo from the 100th dot position (16 characters plus 5 dots), and its program list.

### G COMMODORE

```

10 DATA 8,27,16,0,100
20 DATA 156,162,193,193,182,162,15
30 FOR I=1 TO 12
40 READ A
50 A$=A$+CHR$(A)
60 NEXT
70 OPEN 4,4
80 PRINT#4,A$" COMMODORE"
90 CMD4:LIST

```







READY.

#### 4.6 Repetition of Graphic Data

With SUB code=CHR\$(26), repetition of graphic data can be specified. The format is as follows:

BS	.....	SUB	NUMBER OF REPETITION	DATA
----	-------	-----	----------------------	------

What can be repeated is just a column of graphic. The following example is to draw a graphic with SUB code.

1976		34		
1977		57		
1978		75		
1979		88		
1980			123	
1981				186

```

10 OPEN4,4
20 FORI=0T05
30 READA:A$=A$+CHR$(A):NEXT
40 FORI=0T05:READB:B$=CHR$(B)
50 C$=CHR$(255)+CHR$(59)+CHR$(15)+CHR$(32)
60 D$=STR$(1976+I)
70 PRINT#4,CHR$(15)D$A$B$C$B
80 NEXT
90 CMD4:LIST
100 DATA8,27,16,0,53,26
110 DATA34,57,75,88,123,186

```

READY.

#### 4.7 "CURSOR UP" Mode

With "CURSOR UP" code=CHR\$(145), "CURSOR UP" character mode can be selected. When the unit is turned on, this mode will be automatically selected.

Example

```

*****
*****
*****
*****

```

```

10 OPEN4,4
20 PRINT#4,CHR$(145)SPC(15)"*****"
30 PRINT#4,CHR$(145)SPC(15)"*****"
40 PRINT#4,CHR$(145)SPC(15)"*****"
50 PRINT#4,CHR$(145)SPC(15)"*****"
60 CMD4:LIST

```

READY.

#### 4.8 "CURSOR DOWN" Mode

With "CURSOR DOWN" code=CHR\$(17), "CURSOR DOWN" character mode can be selected.

```
VIC-20 Personal Computer
VIC-1515 Graphic Printer
```

```
10 open4,4,7
20 Print#4,chr$(17)"VIC-20 Personal Computer"
30 Print#4,chr$(17)"VIC-1515 Graphic Printer"
40 cmd4:list
```

ready.

When you want to print a program list also in the "CURSOR DOWN" character mode, you must set up secondary address to 7.

Try to remove 7 in line 10 of the above program, and RUN.

#### 4.9 Reverse Field Mode

With RVS ON code=CHR\$(18), the reverse field mode can be selected.

```
VIC-20 Personal Computer
VIC-1515 Graphic Printer
```

```
10 open4,4,7
20 Print#4,chr$(18)"VIC-20 Personal Computer"
30 Print#4,chr$(18)"VIC-1515 Graphic Printer"
40 cmd4:list
```

ready.

#### 4.10 Rest the Reverse Field Model

With RVS OFF code=CHR\$(146), the reverse field mode can be reset.

```
VIC-20 Personal Computer
VIC-1515 Graphic Printer
```

```
10 open4,4,7
20 Print#4,chr$(18)"VIC-20 Personal Computer"
30 Print#4,chr$(146)"VIC-1515 Graphic Printer"
40 cmd4:list
```

ready.

#### 4.11 Mixture of Various Print Mode

Various print modes can be mixed in one line as follows:

Example

```
G COMMODORE
10 DATA8,27,16,0,36
20 DATA156,156,162,162,193,193
30 DATA193,193,182,182,162,162,14
40 FORI=1TO18
50 READA:A#=A#+CHR$(A)
60 NEXT
70 OPEN1,4
80 PRINT#1,A#" COMMODORE"
90 PRINT#1,CHR$(15)
100 CMD1:LIST
```

READY.

#### 4.12 Line Feed Spacing

Linefeeds are executed in accordance with the print mode in effect just prior to the execution of a print command.

- Character and double width character modes. . . . . 6 LPI
- Graphic mode . . . . . 9 LPI

#### 4.13 Data Buffer Size

The Printer's print-line buffer contains upto 90 bytes of data. At least the first byte is used for the character mode code. Since Printer provides automatic printing, which guarantee no loss of data due to overflow, you do not have to worry about buffer size. Not only the print data, the following will be contained in the buffer.

SI . . . . .	1 byte	NL . . . . .	1 byte
SO . . . . .	1 byte	CR . . . . .	1 byte
POS/HP/LP . . . . .	3 bytes	RVS ON . . . . .	1 byte
ESC/POS/HP/LP . . . . .	3 bytes	RVS OFF . . . . .	1 byte
BS . . . . .	1 byte	CURSOR UP . . .	1 byte
SUB/number of repetition/ mark data . . . . .	3 bytes		

### 5. Automatic Printing

- (1) Printing takes place automatically when either of the two conditions, listed below occurs.





Printing starts  
Printing example

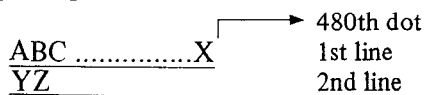

The entire contents of the buffer are printed.

(3) Other cases

The mode in effect during automatic printing remain that which existed just prior to buffer overflow until a mode select change is specified.





## APPENDIX B Hard Copy of the Screen

The following is a sample program to be used when the hard copy of the CRT. This program is made to be used as a sub-routine. Therefore, when you use it, use it as "GOSUB 60000".

```
60000 REM CRT COPY
60010 G1$=CHR$(145)
60020 OPEN4,4:PRINT#4:G1=7658
60030 FORG0=0TO22:G0$=G1$:G1=G1+22
60040 FORG2=G1TOG1+21:G3=PEEK(G2)
60050 IFG3>128THENG3=G3-128:G4=1:G0$=G0$+CHR$(18)
60060 IF(G3>0)*(G3<32)THENG3=G3+64:GOTO60100
60070 IF(G3>31)*(G3<64)THEN60100
60080 IF(G3>63)*(G3<96)THENG3=G3+128:GOTO60100
60090 IF(G3>95)*(G3<128)THENG3=G3+64:GOTO60100
60100 G0$=G0$+CHR$(G3)
60110 IFG4=1THENG0$=G0$+CHR$(146):G4=0
60120 NEXTG2:PRINT#4,G0$:NEXTG0
60130 PRINT#4:CLOSE4
60140 RETURN
```

This program is in the "CURSOR UP" Mode. If you write a program in the "CURSOR DOWN" Mode, you must change G1\$=CHR\$(145) to G1\$=CHR\$(18) in line 60010.

## CAUTION

- Wait at least two seconds to turn on the power after it is turned off, otherwise the Printer will not be initialized properly.
- Never place the Printer where it is exposed to direct sunlight.
- Never apply power while you are plugging in or unplugging an input connector.
- Never turn off the power while the Printer is in motion.
- Never try to move the print head manually, regardless if power is on or off.
- Do not stop the print head motion while it is printing.
- Do not print without paper and/or ribbon because the print head might be damaged.
- Turn off the power quickly and remove a foreign object, if you drop it into the Printer.
- Be sure to use the lock-levers after inserting an input connector into the Printer.
- Do not subject the Printer to temperatures below 5°C or above 40°C during operations, or to sudden change in temperature.
- Regarding printing duty.  
In graphic mode, using patterns of too high dot density will wear out the print head faster. We recommend that you use patterns whose dot density is equal to that of ordinary alphanumerics. The continuous printing of high dot density patterns may badly affect the longevity of the print head.
- Unplug the power cord before trying to take off the upper case.

## MAINTENANCE

We hope you don't have problems but just in case . . . see if you can solve them by using the table below. If you can't, then try to determine which component in your system is at fault, and bring it into a store for repair.

Problems	Probable Causes/Solutions
Printer won't print. Power Indicator 'OFF'.	1) Printer power is 'OFF'. Check the connection and the power switch. 2) Fuse may be blown. Replace only with a fuse of the same rating.
Printer won't print. Power Indicator 'ON'.	1) Improper connection. Check the writing of input data to the Printer. 2) Improper ribbon setting. Reset the ribbon
Printer okay, but the paper won't advance.	Paper is jammed. Remove and reload the paper.
Printed characters are too light or smudging.	1) Improper printing pressure. Adjust the lever's position on the print head. 2) Wrong ribbon setting. Reset the ribbon. 3) Old or worn-out ribbon. Replace the ribbon.

**WARNING:** This equipment has been certified to comply with the limits for a Class B computing device, pursuant to Subpart J of Part 15 of FCC Rules. Only computers certified to comply with the Class B limits may be attached to this printer. Operation with noncertified computers is likely to result in interference to radio and TV reception.”

This warning is valid for the equipment which has the following FCC label on its rear.

CERTIFIED TO COMPLY WITH CLASS B LIMITS.  
PART 15 OF FCC RULES SEE INSTRUCTIONS IF  
INTERFERENCE TO RADIO RECEPTION IS SUS-  
PECTED.

User defined machine language IRQ routines should not exceed 10 milliseconds.

If this is done, the printer may give "Device not present" error.



**VIC-1515**

 **commodore**